



Römer Galerie, Leonberg

## GEZE MSW

Manual Sliding Wall System



# GEZE MSW – Manual Sliding Wall System

GEZE MSW is particularly suitable for innovative all glass solutions in pretentious building projects. A flexible building block principle and the integration of panels with different functions offers architects and planners a wide scope of design for the realization of individual sliding walls. The sliding wall system MSW is conceived for hotels and congress halls, banks, shopping arcades, airports and much more. Very good running properties by using high-quality precision ball bearings for the carriage, silent operation, small energy expenditure when manual shifting the glass elements are pointed out.

- ▶ A maximum panel weight of 150 kg can be operated smoothly and with a minimum of noise due to the high quality precision ball bearings. The glass elements can be moved into the desired position with a minimum of effort.
- ▶ The panels are attached for the whole width of the element – at top and bottom – in carrier and clamping profiles. No drilling of the glass panels is required, eliminating the costs for drilling the glass and significantly reducing any associated causes for failure.
- ▶ GEZE MSW is an extremely installation-friendly system. The basic structural design, without the necessity for holes drilling into the glass, allows for a large range of tolerance. The carrier and clamping profiles can be pre-fitted in the works, allowing for a fast and error-free installation of the clamping profiles.
- ▶ Another advantage of the product is that the covers for carrier and clamping profiles can be clipped. The covers can be clipped on after installation has been completed. This gives added protection of the surfaces against damage and scratching during installation. If there is any damage at a later point, the profiles can be easily and swiftly replaced.
- ▶ The parking area for the divider elements can be arranged in parallel, 90° to the sliding axis or as a special parking recess.
- ▶ The selection of different surfaces and colours available provides architects and designers a good range of design options. The manual sliding wall system GEZE MSW fits well into the overall design of buildings of any style.

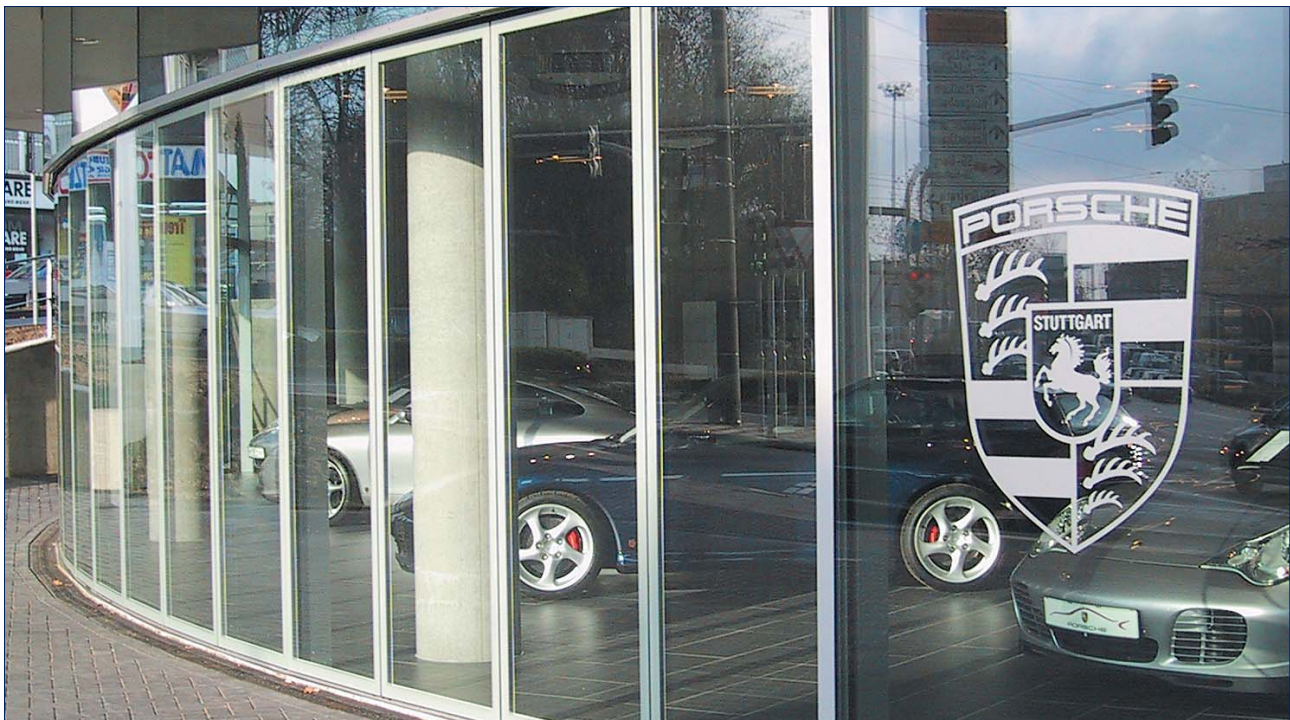

## Sliding glass element as single- or double-action door (SBT)

Flexibility by functionality are the characteristics which make the GEZE MSW an outstanding system. Especially with SBT, sliding glass element as single- respectively double-action door.

The layout of sales areas and the presentation of goods are important factors for success of a shopping center. The wide glass elements of the GEZE MSW sliding wall system offer clear view and can also be used as single- or double-action doors with closing function.

If the MSW shop front is not to be opened, the sales areas can be entered by the single-action respectively double-action door. With only a few movements, an easy to handle mechanical locking device makes a fully functional swing door from a closed sliding element. By the use of two sliding glass elements as single-action or double-action door, wide openings can be realized.

The following variants of SBT, sliding glass elements as single- or double-action doors are available:

- ▶ Sliding glass element as double-action door with floor spring GEZE TS 520
- ▶ Sliding glass element as single-action door with overhead door closer GEZE TS 3000 V
- ▶ Standard sliding glass element as single-action door



## Technical details

Technical data of the manual sliding wall GEZE MSW:

- ▶ max. clear passage height 3500 mm
- ▶ max. panel width 1500 mm max.
- ▶ panel weight
  - up to 100 kg with single carriage
  - up to 150 kg with double carriage

The parking area for the divider elements can be arranged in parallel, at 90° to the sliding axis or as a special parking recess. All parking spaces can be designed with or without parking space screens, i.e. both double tracks as well as single tracks can be used.

The surfaces of the running track have a standard anodised aluminium finish in the colour EV1. When using a double running track it is also possible to use different types of anodised finish as well as powder coating in RAL colours. The geometry of the running tracks of the GEZE MSW manual sliding wall can be arranged straight, in a continuous curve or polygonally.

The glass panels of the GEZE MSW manual sliding wall system are held at the top and bottom over the whole width of the element by carrier and clamping profiles. Clip-on covers for the carrier and clamping profiles are available in two different versions:

- ▶ following the contour of the carrier and clamping profile (standard)
- ▶ rectangular in shape

Horizontally the panel elements are sealed at the top and bottom through sealing brushes.

On request it is possible to supply a continuous floor track for the GEZE MSW manual sliding wall.

### Bolting/locking

- ▶ Floor bolting
- ▶ Single lever safety lock (as floor lock) for profile cylinder with square lock nut



# MSW – Monoglass

## Glass panel versions

- ▶ All-glass panels with continuous carrier and clamping profiles at top and bottom, ESG, toughened glass 10 mm or 12 mm thick
- ▶ GEZE IGG Integrated all-glass system with surrounding edge printing. Standard construction provides 2 x 6 ESG, toughened glass with an inter-pane gap (SZR) of 27 mm

## Panel variations

The following panel options are available with the GEZE MSW system:

- ▶ Horizontally fixed panels:
  - as double-action door with floor spring GEZE TS 550
  - as swing door with floor bearing
  - as single-action door with external pivot bearing
  - as fixed panel
- ▶ Horizontally moveable panels:
  - as sliding door
- ▶ Sliding glass element as double-action door (SBT) (not for GEZE IGG)

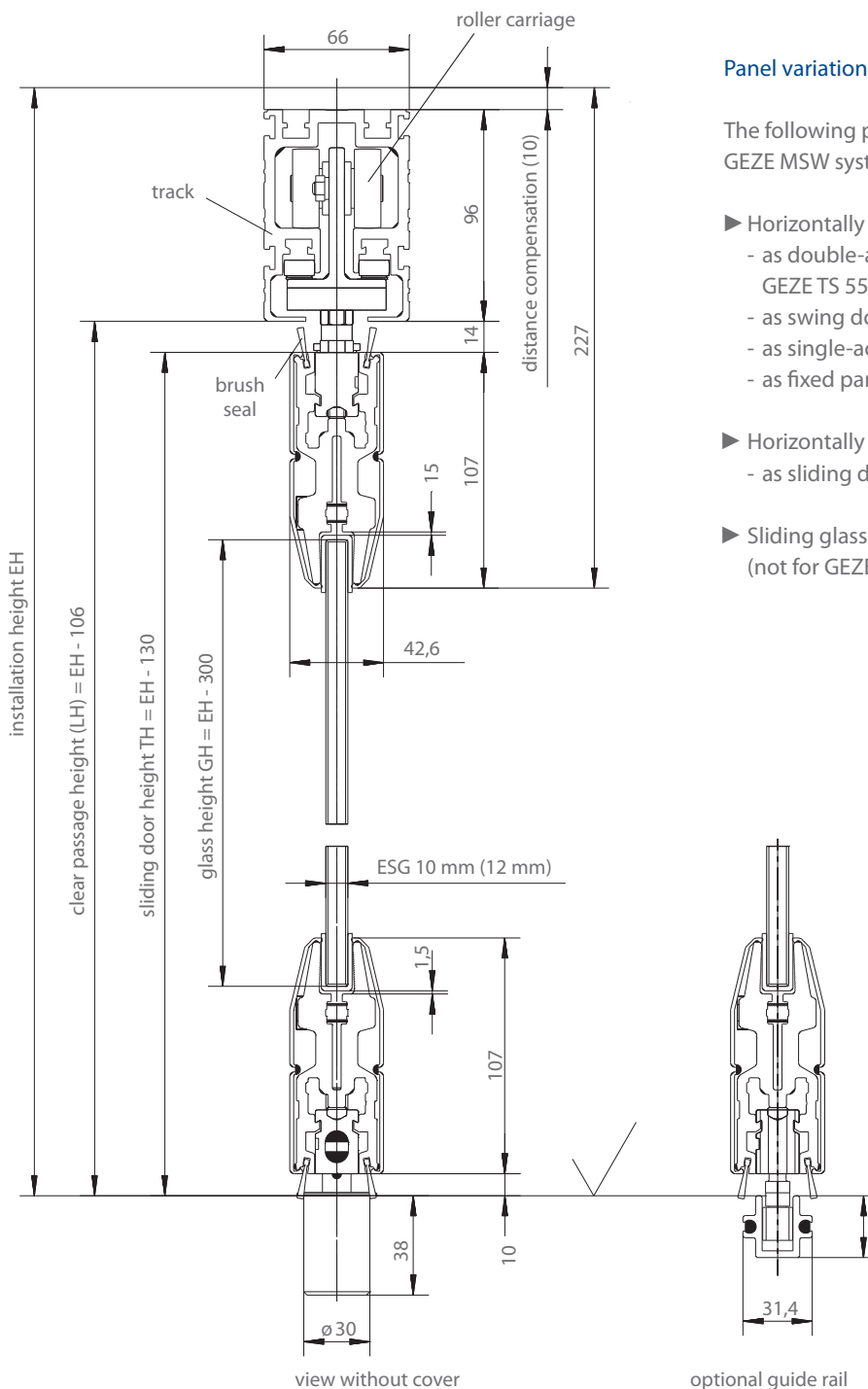

## Cover options for carrier and clamping profiles

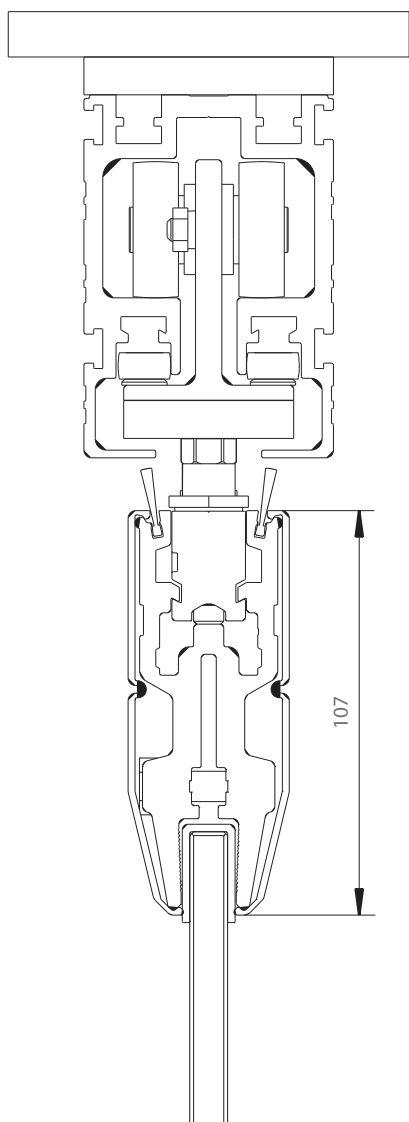

standard

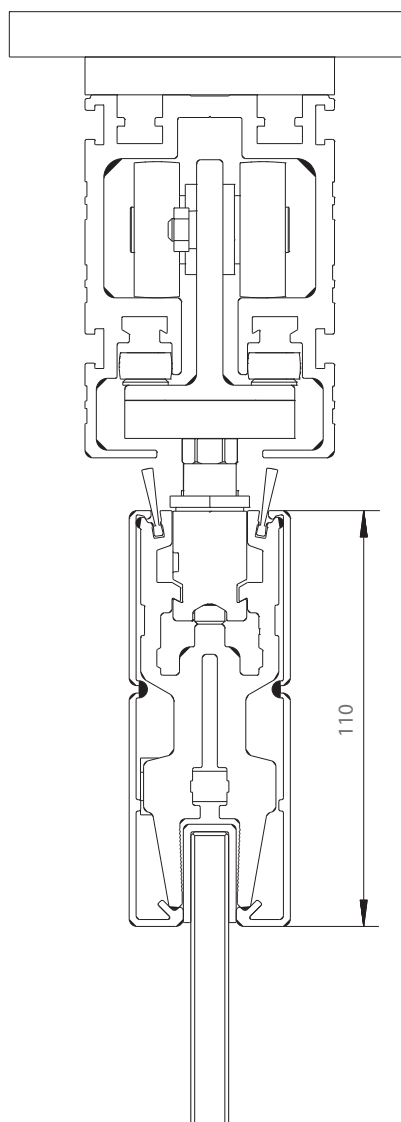

rectangular

## GEZE MSW – Specification text

Manual sliding wall system GEZE MSW fluently sliding manner by cornering technique, fitting- and operating-parts integrated in profile,

Max. door weight: 150 kg

Dimensions:

width: approx. .... mm (max. 1500 mm/door)

height: approx. .... mm (max. 3500 mm/door)

Running track:

- straight
- bent, radius .... mm (door straight, with that general view polygonal)
- changes of dimension, angle ....°

Finish:

- without floor guide rail
- with floor guide rail

Division of leaves:

- .... pcs. double-action door, fixed with floor spring GEZE TS 550
- .... pcs. single-action door, fixed without floor spring
- .... pcs. sliding doors
- .... pcs. fixel panels
- sliding glass element as single-action or double-action door

Technical features of the sliding glass element as single-action door or double-action door:

door height: max. 3000 mm

door width: max. 1100 mm

door weight: max. 90 kg

- .... pcs. sliding glass element as double-action door with floor spring GEZE TS 520
- .... pcs. sliding glass element a swing door with floor bearing
- .... pcs. sliding glass element a single-action door with overhead door closer GEZE TS 3000 V

Cover profile:

- according to the shape of the fitting- and clamping profiles, height 107 mm
- rectangular height H = 110 mm
- EV1 anodised (standard)
- powder coated RAL ....
- stainless steel design, anodised

Swing door locking:

floor lock for profile cylinder (lift 19 mm)

Parking space:

- with single running track (uncovered)
- with double running track (covered)

single-sided

- left (view from inside)
- right (view from inside)

double-sided

Parking space arrangement:

- 90° to the line of sliding wall
- parallel to the line of sliding wall
- special parking space according to drawing

Glass:

- ESG, toughened safety glass 10 mm (green glass)
- ESG, toughened safety glass 10 mm, Diamant (white glass)
- ESG, toughened safety glass 12 mm (green glass)
- ESG, toughened safety glass 12 mm, Diamant (white glass)
- IGG (ESG 6 mm - SZR 27 mm - ESG 6 mm) not for sliding glass elements as double-action door
  - imprint:
    - bottom and top, width 50 mm
    - left / right, width 45 mm
  - special:
    - left/right: .... mm (min. 30 mm)
  - colour imprint: according to RAL ....

Surface finishing of glass:

- silk-screen print, specification:
- protection against the sun coating, specification:
- special coating:

Seal:

- horizontal brush seal

**GEZE GmbH**

P.O. Box 1363  
71226 Leonberg  
Germany

**GEZE GmbH**

Reinhold-Vöster-Straße 21-29  
71229 Leonberg  
Germany  
Telefon +49 (0) 7152-203-0  
Telefax +49 (0) 7152-203-310

**GEZE Online:**

[www.geze.com](http://www.geze.com)

**GEZE branch offices****Germany****GEZE GmbH**

Niederlassung Nord/Ost  
Bühningstraße 8  
13086 Berlin (Weissensee)  
Tel. +49 (0) 30-47 89 90-0  
Fax +49 (0) 30-47 89 90-17  
E-mail: berlin.de@geze.com

**GEZE GmbH**

Niederlassung West  
Nordsternstraße 65  
45329 Essen  
Tel. +49 (0) 201-83082-0  
Fax +49 (0) 201-83082-20  
E-mail: essen.de@geze.com

**GEZE GmbH**

Niederlassung Mitte  
Adenauerallee 2  
61440 Oberursel (b. Frankfurt)  
Tel. +49 (0) 6171-63610-0  
Fax +49 (0) 6171-63610-1  
E-mail: frankfurt.de@geze.com

**GEZE GmbH**

Niederlassung Süd  
Reinhold-Vöster-Straße 21-29  
71229 Leonberg  
Tel. +49 (0) 7152-203-594  
Fax +49 (0) 7152-203-438  
E-mail: leonberg.de@geze.com

**GEZE subsidiaries****Germany**

**GEZE** Sonderkonstruktionen  
GmbH  
Planken 1  
97944 Boxberg-Schweigern  
Tel. +49 (0) 7930-9294-0  
Fax +49 (0) 7930-9294-10  
E-mail: sk.de@geze.com

**GEZE** Service GmbH

Reinhold-Vöster-Straße 25  
71229 Leonberg  
Tel. +49 (0) 7152-9233-0  
Fax +49 (0) 7152-9233-60  
E-mail: info@geze-service.com

**GEZE** Service GmbH

Niederlassung Berlin  
Bühningstraße 8  
13086 Berlin (Weissensee)  
Tel. +49 (0) 30-470217-30  
Fax +49 (0) 30-470217-33

**Europa****Benelux**

**GEZE** Benelux B.V.  
Leemkuil 1  
Industrieterrein Kapelbeemd  
5626 EA Eindhoven  
Tel. +31 (0) 40-26290-80  
Fax +31 (0) 40-26290-85  
E-mail: benelux.nl@geze.com

**France**

**GEZE** France S.A.R.L.  
ZAC de l'Orme Rond  
RN 19  
77170 Servon  
Tel. +33 (0) 1-60626070  
Fax +33 (0) 1-60626071  
E-mail: france.fr@geze.com

**Great Britain**

**GEZE** UK Ltd.  
Blenheim Way  
Fradley Park  
Lichfield  
Staffordshire WS13 8SY  
Tel. +44 (0) 1543-443000  
Fax +44 (0) 1543-443001  
E-mail: info@geze-uk.com

**Italy**

**GEZE** Italia Srl  
Via Giotto 4  
20040 Cambiago (MI)  
Tel. +39 02 95 06 95-11  
Fax +39 02 95 06 95-33  
E-Mail [italia.it@geze.it](mailto:italia.it@geze.it)

**GEZE** Engineering Roma Srl

Via Lucrezia Romana 91  
00178 Roma  
Tel. +39 06-7265311  
Fax +39 06-72653136  
E-mail: [gezeroma@libero.it](mailto:gezeroma@libero.it)

**GEZE** Engineering Bari Srl

Via Treviso 58  
70022 Altamura (Bari)  
Tel. +39 080-3115219  
Fax +39 080-3164561  
E-mail: [gezebari@libero.it](mailto:gezebari@libero.it)

**Austria**

**GEZE** Austria GmbH  
Mayrwiesstraße 12  
5300 Hallwang b. Salzburg  
Tel. +43 (0) 662-663142  
Fax +43 (0) 662-663142-15  
E-mail: [austria.at@geze.com](mailto:austria.at@geze.com)

**Poland**

**GEZE** Polska Sp. z o.o.  
ul. Annopol 3 (Zeran Park)  
03-236 Warszawa  
Tel. +48 (0) 22-8142211  
Fax +48 (0) 22-6142540  
E-mail: [geze@geze.pl](mailto:geze@geze.pl)

**Switzerland**

**GEZE** Schweiz AG  
Bodenackerstrasse 79  
4657 Dulliken  
Tel. +41 (0) 62-285 54 00  
Fax +41 (0) 62-285 54 01  
E-mail: [schweiz.ch@geze.com](mailto:schweiz.ch@geze.com)

**Spain**

**GEZE** Iberia S.R.L.  
Pol. Ind. El Pla  
C/ Comerc, 2-22, Nave 12  
08980 Sant Feliu de Llobregat  
(Barcelona)  
Tel. +34-(0) 9-02 19 40 36  
Fax +34-(0) 9-02 19 40 35  
E-mail: [iberia.es@geze.com](mailto:iberia.es@geze.com)

**Scandinavia****Sweden**

**GEZE** Scandinavia AB  
Mallslingan 10  
Box 7060  
18711 Täby  
Tel. +46 (0) 8-7323-400  
Fax +46 (0) 8-7323-499  
E-mail:  [sverige.se@geze.com](mailto: sverige.se@geze.com)

**Norway**

**GEZE** Scandinavia AB avd. Norge  
Postboks 63  
2081 Eidsvoll  
Tel. +47 (0) 639-57200  
Fax +47 (0) 639-57173  
E-mail: [norge.se@geze.com](mailto:norge.se@geze.com)

**Finland**

**GEZE** Finland  
Branch office of  
**GEZE** Scandinavia AB  
Postbox 20  
158 71 Hollola  
Tel. +358 (0) 10-400 51 00  
Fax +358 (0) 10-400 51 20  
E-mail: [finland.se@geze.com](mailto:finland.se@geze.com)

**Denmark**

**GEZE** Denmark  
Branch office of  
**GEZE** Scandinavia AB  
Møllehusene 3, 3. th.  
4000 Roskilde  
Tel. +45 (0) 46-323324  
Fax +45 (0) 46-323326  
E-mail:  [danmark.se@geze.com](mailto: danmark.se@geze.com)

**Middle East****U.A.E.**

**GEZE** Middle East  
P.O. Box 17903  
Jebel Ali Free Zone  
Dubai  
Tel. +971 (0) 4-8833112  
Fax +971 (0) 4-8833240  
E-mail: [geze@emirates.net.ae](mailto:geze@emirates.net.ae)

**Asia**

**GEZE** Asia Pacific Ltd.  
Unit 630, Level 6, Tower 2  
Grand Central Plaza  
138 Shatin Rural Committee  
Road  
Shatin, New Territories  
Hong Kong  
Tel. +852 (0) 237-57382  
Fax +852 (0) 237-57936  
E-mail: [info@geze.com.hk](mailto:info@geze.com.hk)

**GEZE** Industries (Tianjin) Co., Ltd.  
Shuangchenzhong Road  
Beichen Economic Development  
Area (BEDA)  
Tianjin 300400, P.R. China  
Tel. +86 (0) 22-26973995-0  
Fax +86 (0) 22-26972702  
E-mail: [geze@public1.tpt.tj.cn](mailto:geze@public1.tpt.tj.cn)

**GEZE** Industries (Tianjin) Co., Ltd.  
Branch Office Shanghai  
Dynasty Business Center  
Room 401-402  
No. 457 WuRuMuQi North Road  
200040 Shanghai, P.R. China  
Tel. +86-(0)21-52 34 09-60/-61/-62  
Fax +86-(0)21-52 34 09-63  
E-mail: [gezesh@geze.com.cn](mailto:gezesh@geze.com.cn)

**GEZE** Industries (Tianjin) Co., Ltd.  
Branch Office Guangzhou  
Room 1113, Jie Tai Plaza  
218-222 Zhong Shan Liu Road  
510180 Guangzhou  
P.R. China  
Tel. +86 (0) 20-813207-02  
Fax +86 (0) 20-813207-05  
E-mail: [gezegz@public2.sta.net.cn](mailto:gezegz@public2.sta.net.cn)

**GEZE** Industries (Tianjin) Co., Ltd.  
Branch Office Beijing  
The Grand Pacific Building  
B Tower Room 201  
8 A, Guanghua Road  
Chaoyang District  
100026 Beijing, P.R. China  
Tel. +86-(0)10-65 81 57-32/-42/-43  
Fax +86-(0)10-65 81 57 33  
E-mail: [gezebj@geze.com.cn](mailto:gezebj@geze.com.cn)

**GEZE** Asia Sales Ltd.  
No. 88-1-408, East Road  
Free Trade Zone of Tianjin Port  
Tianjin, P.R. China  
Tel. +86 (0)22-26 97 39 95-0  
Fax +86 (0)22 26 97 27 02  
E-mail: [geze@public1.tpt.tj.cn](mailto:geze@public1.tpt.tj.cn)