

GEZE TS 430/8000

CONCEALED OVERHEAD
DOOR CLOSERS

DOUBLE OR SINGLE ACTING CENTRE PIVOTED SIDE AND END LOADING

IMPORTANT

This closer should be installed by a competent fixer who must pass these instructions on to the site or maintenance manager once the closer has been satisfactorily fixed. No responsibility can be accepted by the manufacturers if these installation instructions are disregarded.

HOLD OPEN OPTIONS

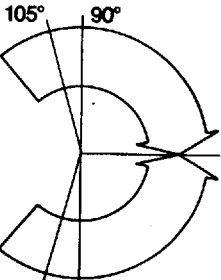

CLOSING RANGE AND ADJUSTMENT

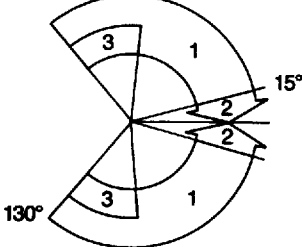

- 1. CLOSING RANGE
- 2. LATCHING RANGE
- 3. BACKCHECK ZONE

ADJUSTING VALVES FOR LATCHING & CLOSING SPEEDS



MAXIMUM 2 TURNS IN EITHER DIRECTION

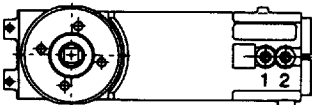

DOOR STOPS MUST BE FITTED, TO PREVENT DOOR OPENING BEYOND 130°

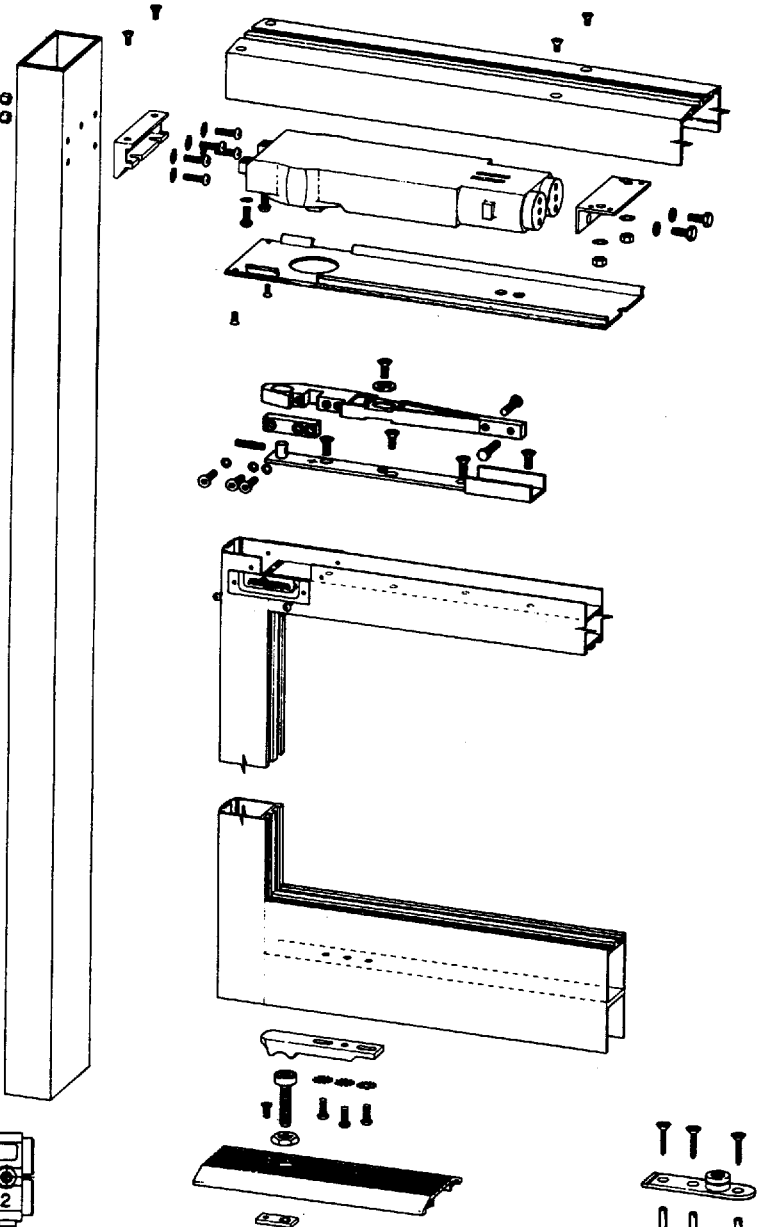

PREPARATION

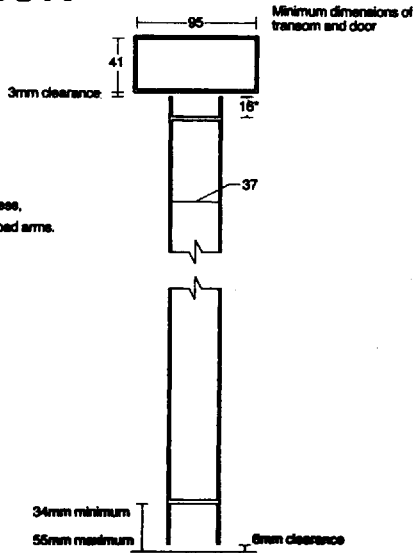

* For door rails with 21mm recess, 5mm shim bar is supplied with end-load arms.

Prepare transom and cover plate to accept closer mechanism as detailed. Fix jamb bracket to side frame with 5 No. M5 r/h screws, washers and nuts. Fix angle bracket to inside of transom with 2 No. M6 csk screws provided.

Locate closer into jamb bracket and swing mechanism up into transom. Secure mechanism to brackets with screws, bolts and washers provided. Secure cover plate to transom.

TRANSOM/HEADER BAR, 70mm PIVOT POINT

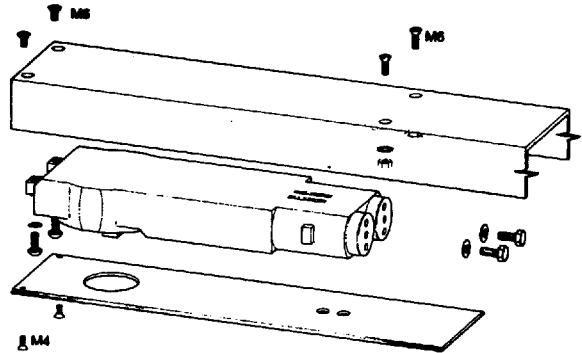
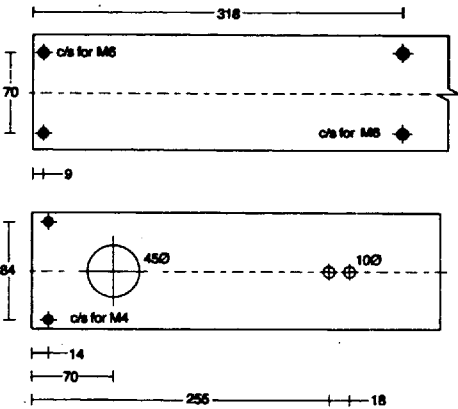

HINGE JAMB

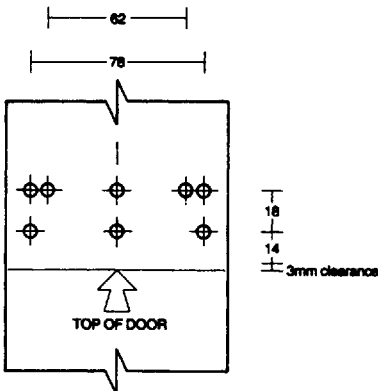

Select fixing holes most suitable for section and drill clearance size for M5 screws.

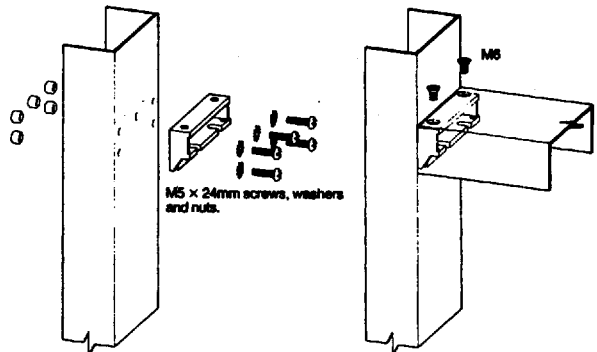

SIDE-LOAD, 70mm PIVOT POINT

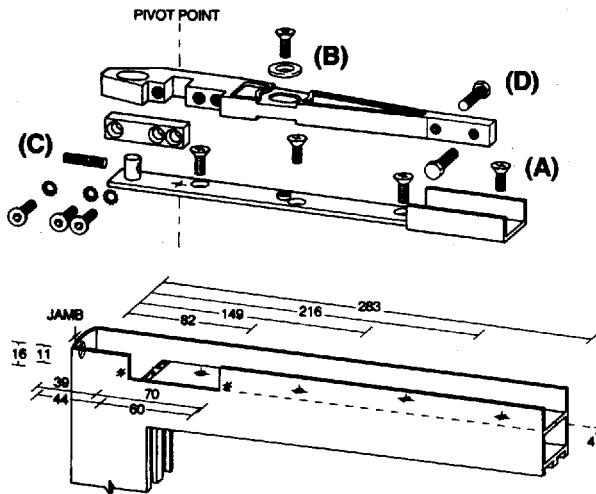

DOOR, TOP RAIL

Prepare top rail of door as detailed, ensuring that internal door face is cut away to give access to spindle during door hanging and hole to be drilled in heel of door to give access to adjustment screw (C).

*Fix arm channel to top rail with 4 No. M6 csk screws (A). Insert arm into channel and secure with M6 csk socket head screw (B).

Insert M6 socket head alignment bolt, washer and locknut (C) into arm through slot in end of channel.

Adjust alignment bolts (D) onto side of channel.

*Note: Datum hole indicating pivot point.

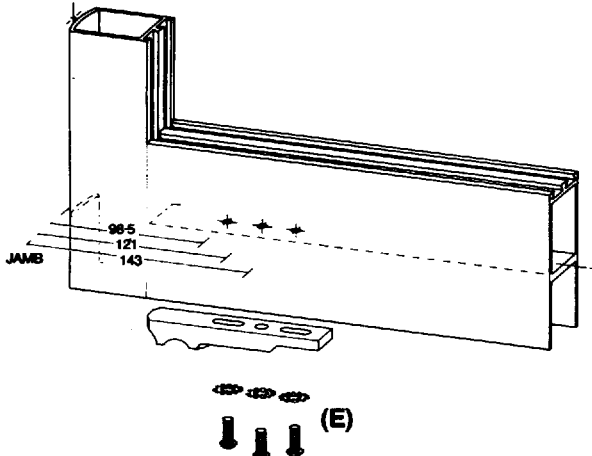

BOTTOM RAIL

Prepare bottom rail of door as detailed.

Secure door plate of bottom pivot assembly to bottom rail of door with 2 No. M6 x 16mm long set screws and shakedown washers (E) using only the slotted holes.

Check that projection of the bearing plate beyond the heel of the door gives the working clearance required.

Slacken the 2 fixed set screws and adjust if necessary. Finally drill and tap bottom rail for 3rd M6 x 16mm long set screw and fix screw to maintain this position. Tighten all screws.

FLOOR PIVOT

Determine overall height of bottom pivot assembly, allowing desired clearance, and secure with locknut. Cut off excess thread flush with underside of plate or recess flooring to accommodate.

Fix bearing plate on to the floor with the extended end against the face of the jamb.

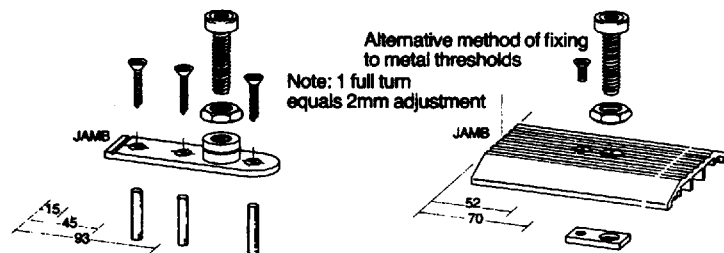

TO ERECT THE DOOR

Holding door at an angle of approx. 15°, lower on to bearing plate pivot and gradually swing door vertical until arm recess in top of door locates against closer spindle.

Note: To ease the hanging of single action doors, temporarily remove head stop if possible. Wedge door in the vertical position whilst spindle clamping block is located against spindle and securely tighten clamping screws using wrench key provided. (Max. tightness can be obtained by using the palm of the hand against the wrench key).

Fit 'cut out' cover plate.

Check that door closes to a position that aligns with door frame or adjacent door leaf. Any correction is obtained by adjusting alignment bolts (D) and alignment screw (C).

END-LOAD, 70mm PIVOT POINT

DOOR, TOP RAIL

Prepare top rail of door as detailed, ensuring heel of door is cut away to give access to spindle during door hanging.

*Fix arm channel to top rail with 4 No. M6 csk screws (A). Insert arm into channel and secure with M6 socket head screw (B).

Insert M6 socket head alignment bolt, washer and locknut (C) into arm through slot in end of channel.

Adjust alignment bolts (D) on to side of channel.

*Note: Datum hole indicating pivot point.

BOTTOM RAIL

Prepare bottom rail of door as detailed, ensuring heel of door is cut away to allow for loading of floor pivot.

Secure door plate of bottom pivot assembly to bottom rail of door with 2 No. M6 x 16mm long set screws and shakeproof washers (E) using only the slotted holes. Check that projection of the bearing plate beyond the heel of the door gives the working clearance required.

Slacken the 2 fixed set screws and adjust if necessary. Finally drill and tap bottom rail for 3rd M6 x 16mm long set screw and fix screw to maintain this position. Tighten all screws.

FLOOR PIVOT

Determine overall height of bottom pivot assembly, allowing desired clearance, and secure with locknut. Cut off excess thread flush with underside of plate or recess flooring to accommodate. Fix bearing plate on to the floor with the extended end against the face of the jamb.

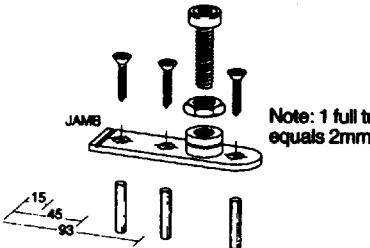
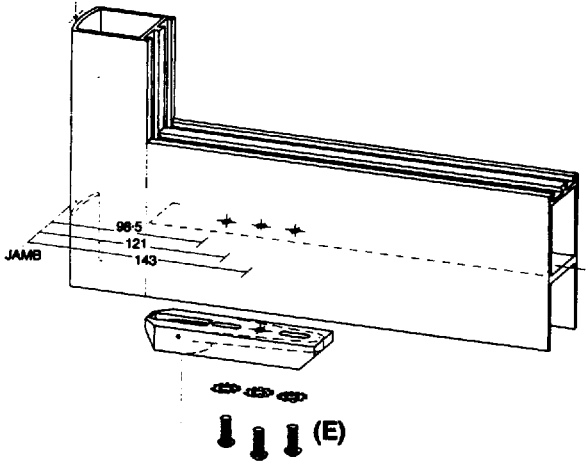
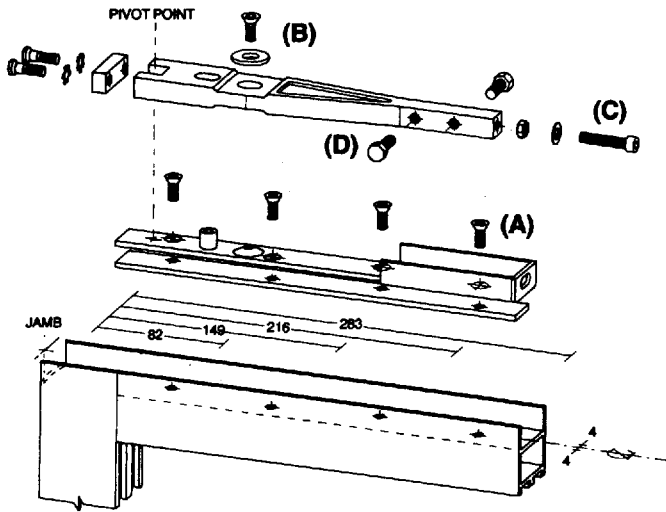

Alternative method of fixing to metal thresholds

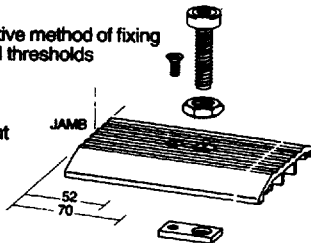

TO ERECT THE DOOR

Pairs of doors

Slide heel end of first door on to top and bottom pivots. Open first door to 90° and wedge or hold open. Fit and firmly secure clamp block to arm with 2 cap head screws and lockwashers. Slide second door over pivots and secure as first door. Fix cover plates to heel cutouts.

Single door

Turn spindle to hold open position or in the case of a no hold open closer, screw in door closing speed regulator and turn spindle through 90°. Slow return of spindle will allow door to be slid on to pivots from the open position. Fit and firmly secure clamp block to arm with 2 cap head screws and lockwashers. Fix cover plates to heel cutouts.

Check that door closes to a position that aligns with door frame or adjacent door leaf. Any correction is obtained by adjusting alignment bolts (D) (C).

END-LOAD, 30mm PIVOT POINT

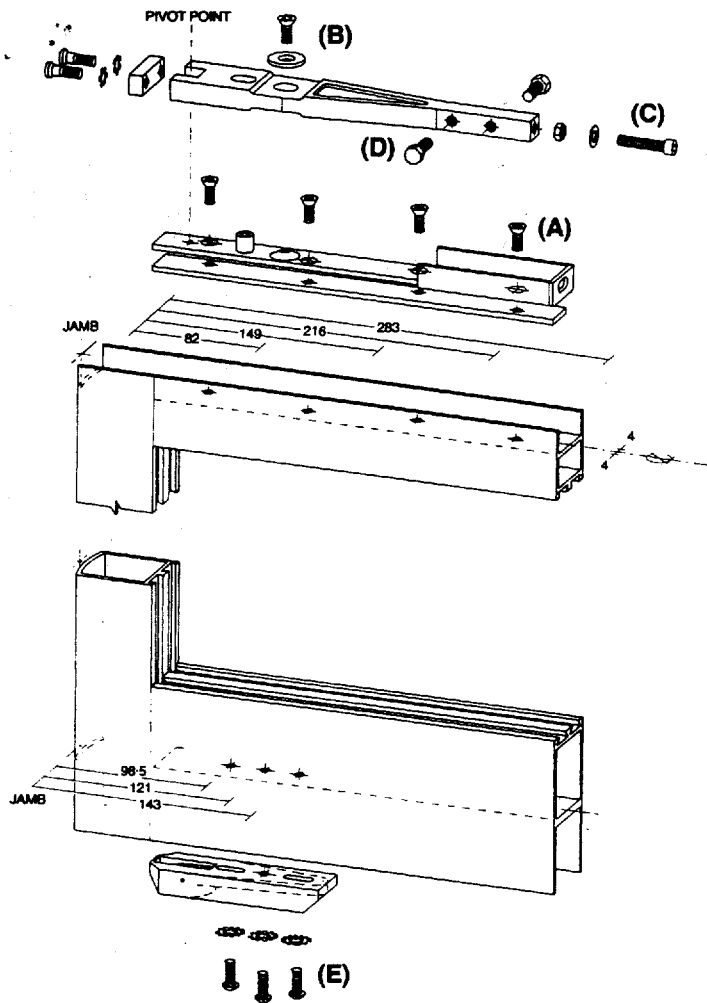

DOOR, TOP RAIL

Prepare top rail of door as detailed, ensuring heel of door is cut away to give access to spindle during door hanging.

*Fix arm channel to top rail with 4 No. M6 csk screws (A). Insert arm into channel and secure with M6 socket head screw (B).

Insert M6 socket head alignment bolt, washer and locknut (C) into arm through slot in end of channel.

Adjust alignment bolts (D) on to side of channel.

*Note: Datum hole indicating pivot point.

BOTTOM RAIL

Prepare bottom rail of door as detailed, ensuring heel of door is cut away for loading of floor pivot.

Secure door plate of bottom pivot assembly to bottom rail of door with 2 No. M6 x 16mm long set screws and shakeproof washers (E) using only the slotted holes.

Check that projection of the bearing plate beyond the heel of the door gives the working clearance required.

Slacken the 2 fixed set screws and adjust if necessary. Finally drill and tap bottom rail for 3rd M6 x 16mm long set screw and fix screw to maintain this position. Tighten all screws.

FLOOR PIVOT

Determine overall height of bottom pivot assembly, allowing desired clearance, and secure with locknut. Cut off excess thread flush with underside of plate or recess flooring to accommodate.

Fix bearing plate on to the floor with the extended end against the face of the jamb.

Alternative method of fixing to metal thresholds

Note: 1 full turn equals 2mm adjustment

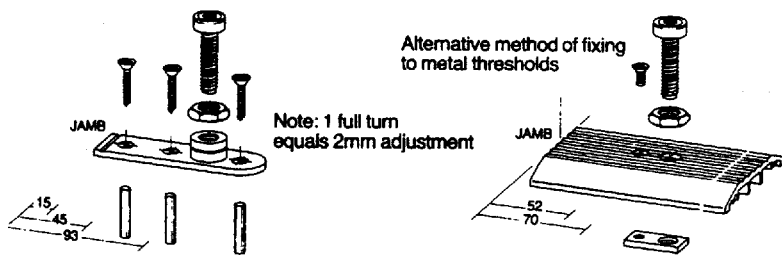

TO ERECT THE DOOR

Pairs of doors

Slide heel end of first door on to top and bottom pivots. Open first door to 90° and wedge or hold open. Fit and firmly secure clamp block to arm with 2 cap head screws and lockwashers. Slide second door over pivots and secure as first door. Fix cover plates to heel cutouts.

Single door

Turn spindle to hold open position or in the case of a no hold open closer, screw in door closing speed regulator and turn spindle through 90°. Slow return of spindle will allow door to be slid on to pivots from the open position. Fit and firmly secure clamp block to arm with 2 cap head screws and lockwashers. Fix cover plates to heel cutouts.

Check that door closes to a position that aligns with door frame or adjacent door leaf. Any correction is obtained by adjusting alignment bolts (D) (C).

PRÉPARATION

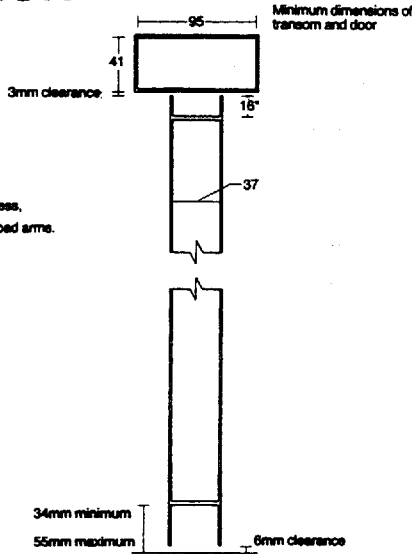

* For door rails with 21mm recess, 5mm shim bar is supplied with end-load arms.

Prepare transom and cover plate to accept closer mechanism as detailed. Fix jamb bracket to side frame with 5 No. M5 r/h screws, washers and nuts. Fix angle bracket to inside of transom with 2 No. M6 csk screws provided.

Locate closer into jamb bracket and swing mechanism up into transom. Secure mechanism to brackets with screws, bolts and washers provided. Secure cover plate to transom.

TRANSOM/HEADER BAR, 70mm PIVOT POINT

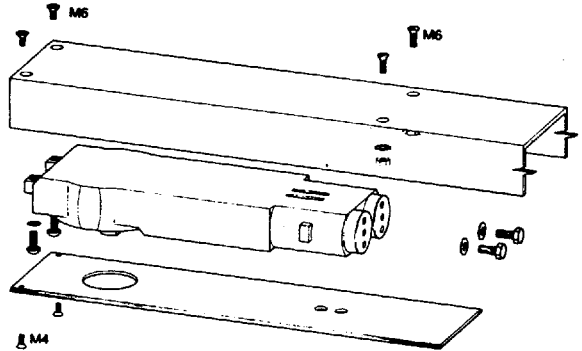
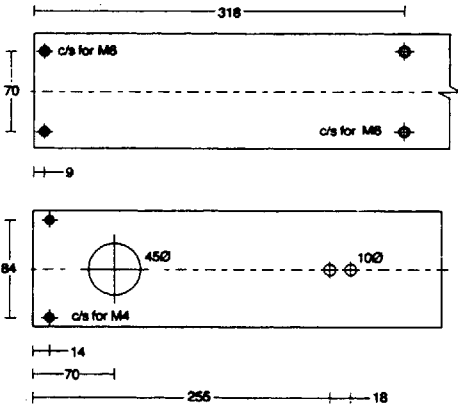

HINGE JAMB

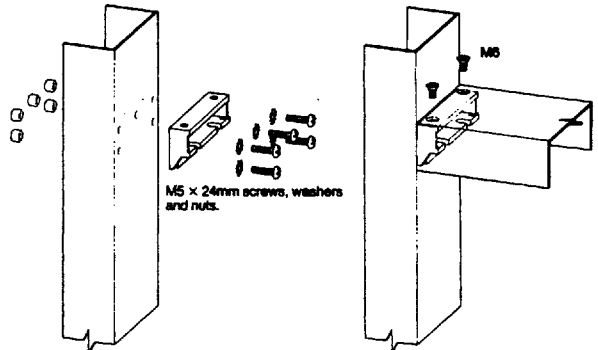
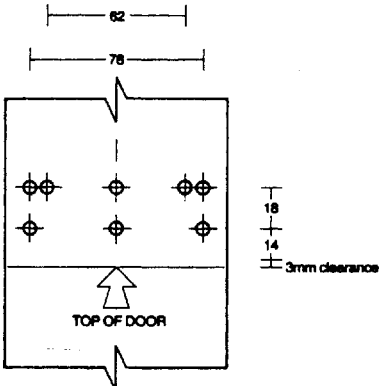

Select fixing holes most suitable for section and drill clearance size for M6 screws.

Pivot bearing

Pivot bearing with flat-conical spindle

see Fig. 13

| Description | Max. door weight | Finish | ID No. |
|----------------------------------------------------------------------|------------------|-----------------|--------|
| Pivot bearing GEZE TS 137 b 75 x 70 mm with square spindle | 250 kg | - | 009788 |
| Small cover plate 80 x 72 mm for pivot bearing | - | Stainless steel | 012846 |

The pivot bearings are available with 5 mm extended spindle.

Pivot bearing with square spindle

| Description | Max. door weight | Finish | ID No. |
|---------------------------------------------------------|------------------|-----------------|--------|
| Pivot bearing GEZE TS 32 b with nylon bearing | 250 kg | - | 010556 |
| Small cover plate 80 x 72 mm for pivot bearing | - | Stainless steel | 012846 |

The pivot bearings are available with 5 mm extended spindle.

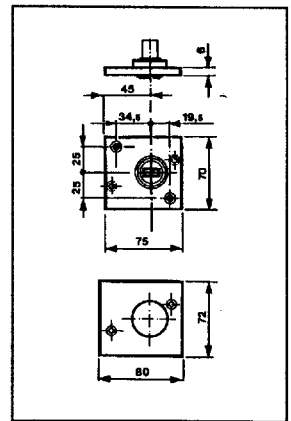

Fig. 13